

**PX0408**



**Summary**

Welcome to the PX series DMX512/ RDM decoding drive. The PX series adopts advanced microcomputer control technology, and converts the widely adopted DMX-512/1990 and RDM/2009 standard digital control signals into analog control signals. 1-4 output channels can be selected, and 256-level control levels can be implemented for each channel. The invention can be used for the connection of the computer digital output light-adjusting table and the analog silicon box, and the use occasions of the control of the LED lamp for the building and the lamp decoration.

1. The product has 4 channels output. The maximum 8A current per channel and the total power up to 768W.
2. Set the address with the dial switch, and the operation is simple and quick.
3. Euro terminal blocks and RJ45 two DMX interfaces are provided to improve signal transmission efficiency and anti-interference capability.
4. With the RDM remote management protocol, the RDM master can browse and set the parameters, the DMX address modification, the device identification and other operations through the RDM master control.
5. It has the functions of short-circuit, over-temperature, overload automatic protection and recovery.
6. Fast self-test function.

**Product Features**

- Meets DMX512/1990,RDM /2009 protocol
- Supported RDM parameters:  
 DISC\_UNIQUE\_BRANCH  
 DISC\_MUTE  
 DISC\_UN\_MUTE  
 DEVICE\_INFO  
 SOFTWARE\_VERSION\_LABEL  
 DMX512/RDM\_START\_ADDRESS  
 IDENTIFY\_DEVICE  
 MANUFACTURER\_LABEL  
 SUPPORTED\_PARAMETERS

In DMX mode set the DMX address manually by switch; in RDM mode, the host computer address allocation

**Technical Parameter**

Product model:	PX0408
Input signal:	DMX512/ RDM
DMX interface:	RJ45, green terminal
Input voltage:	12-24VDC
Output:	8 A *4 CH.
Output power:	384W (12V)MAX / 768W (24V)MAX
Working temperature:	-20-50 C
product size :	140*50*26mm(L*W*H)
packing measurement :	145*56*32mm(L*W*H)
Weight (net weight) :	240g

**Dimension(mm)**

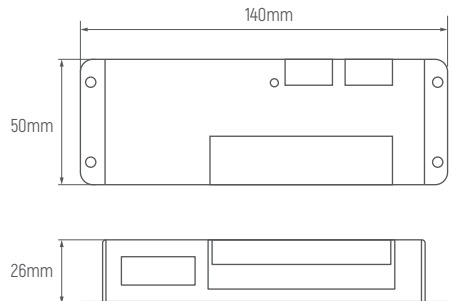

**Interface Description**

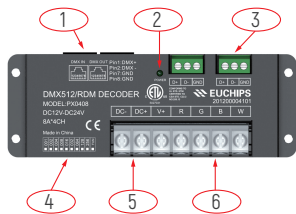

- (1) RJ45 Signal input and output interfaces
- (2) Signal light (The normal signal indicator is green flashing, but if the signal is abnormal, the indicator light is not on.)
- (3) Euro terminal blocks
- (4) Address setting interface
- (5) Power input interface
- (6) Output interface

**DIP Switch Setting**

	DIP1	DIP2	DIP3	DIP4	DIP5	DIP6	DIP7	DIP8	DIP9	DIP10
OFF	0	0	0	0	0	0	0	0	0	NA
ON	1	2	4	8	16	32	64	128	256	FUN

DIP1-9: sets the address of the first channel of DMX decoder, and the corresponding table of dialing switch shows that the sum of numbers is the first channel address of DMX decoder. The valid address in DMX mode is  $1 \leq 511$ , (address 511 is self-test mode, output RGBW gradient). When the address is set to 0, the default is RDM mode.  
 DIP10: FUN represents the end resistance of 120 ohms.

**Connection diagram**

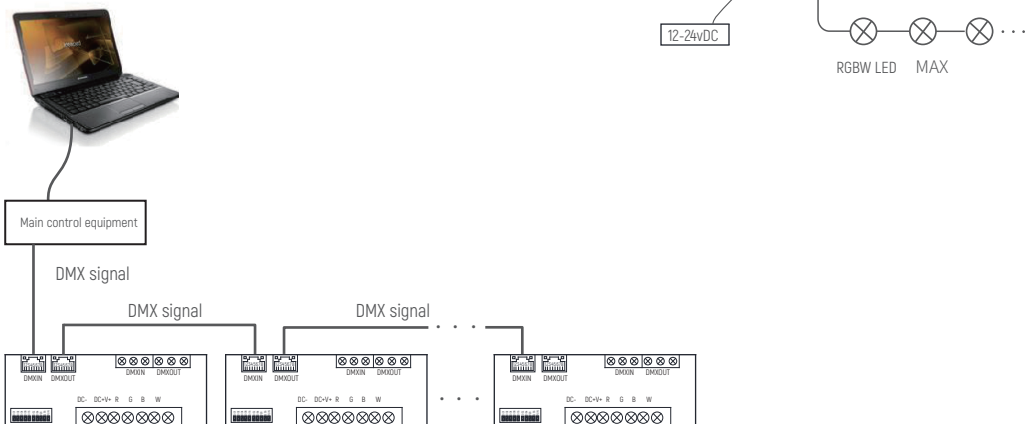

**The Setting Of The Dmx First Address:**



RDM mode: when the code extraction switch 110 is fully turned upward.

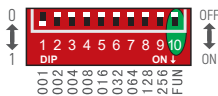

DMX mode: FUN = OFF (when the 10th pull-out switch is up), The DMX address can now be set by the 1-9 dial switch

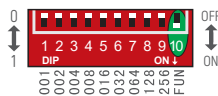

Self-test mode: FUN = OFF (address 511 is self-test mode, output RGBW gradient)

**System connection diagram**

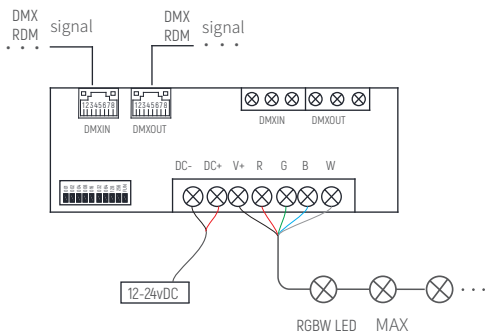

**Hookup**

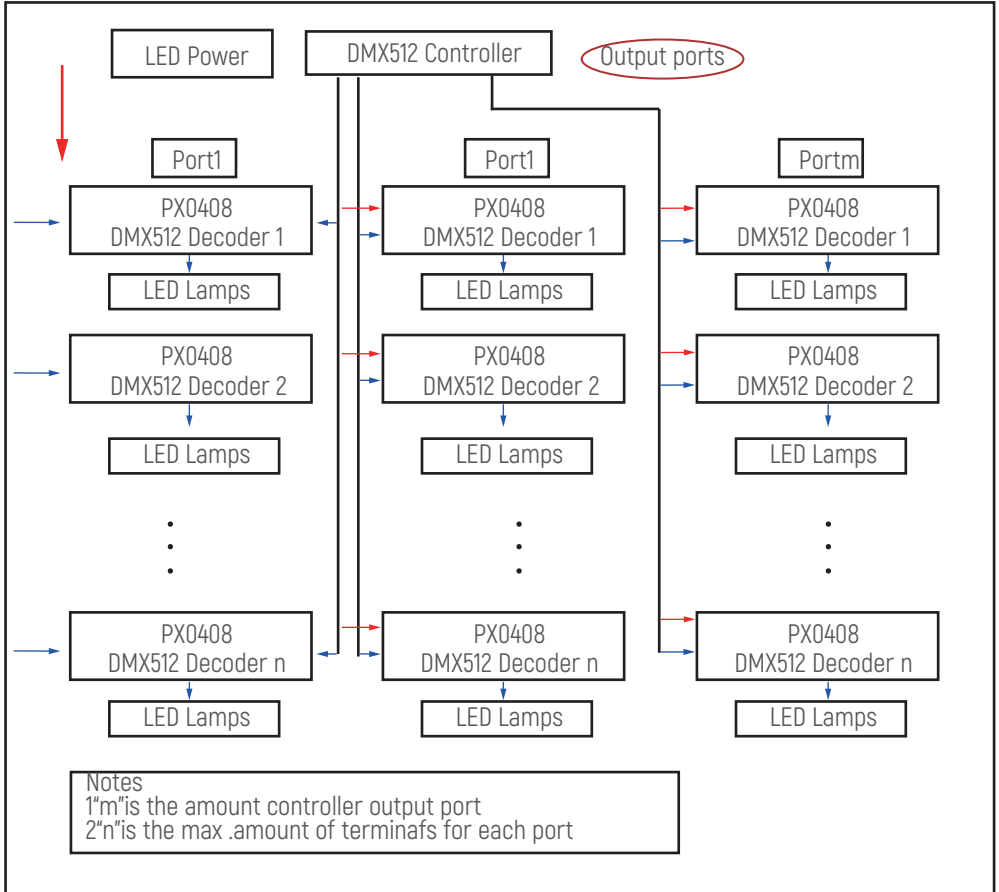

- (1)The DMX512/ RDM is directly connected, and the DMX512/ RDM signal has positive and negative signals. Pay attention to the polarity when wiring. A positive signal, a negative signal, and a ground signal are connected to an interface corresponding to the device
- (2)Refer to "DMX series address dial code table" to set DMX address by dial code switch.
- (3) The tail of the whole wiring needs to be connected to the signal Terminator at the end of the connection.